

SHRINK DİSK - HAFİF HİZMET TORKU GEREKTİREN YERLERE

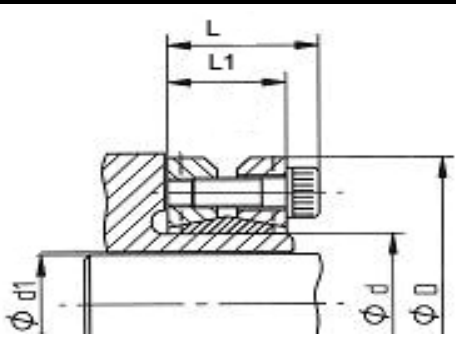

Ma	Vida sıkma döndürme momenti
Mt	Maks.aktarılabilen döndürme momenti (Fass=0 kN)
Fass	Maksimum aktarılabilen aksenal yük (Mt=0 Nm)
Ps	Kovana yapılan basınç

602

ÖLÇÜLER

BAĞLANTI ELEMANI

BAŞARIMLARI

AĞIRLIK

SİPARİŞ KODU	d1	d	D	L1	L	DIN 931		Ma	Mt	Fass	Ps	Kg
	mm	mm	mm	mm	mm	Ad.	10.9 TİP	Nm	Nm	Kn	N/mm ²	
CTL602 - 125	85	125	190	52	59	8	M10	59	10.600	225	99	6
	90								12.800	258	111	
	95								15.300	292	125	
CTL602 - 140	95	140	220	52	59	10	M10	59	18.200	331	126	8
	100								23.900	399	149	
	105								26.700	428	160	
CTL602 - 155	105	155	245	52	59	12	M10	59	30.100	464	154	10
	110								33.700	500	166	
	115								37.600	537	179	
CTL602 - 165	115	165	260	62	70	10	M12	100	36.300	539	149	14
	120								40.500	579	159	
	125								44.800	619	170	
CTL602 - 175	125	175	275	62	70	10	M12	100	40.000	552	142	16
	130								44.200	590	152	
	135								48.700	629	162	
CTL602 - 185	135	185	295	62	70	12	M12	100	53.900	697	168	20
	140								58.900	737	177	
	145								64.100	777	188	
CTL602 - 195	145	195	315	72	80	15	M12	100	73.300	889	171	27
	150								79.500	936	180	
	155								86.100	984	189	
CTL602 - 220	160	220	345	84	94	10	M16	250	99.800	1.109	185	35
	165								111.800	1.177	171	
	170								128.600	1.287	186	
CTL602 - 240	170	240	370	84	94	12	M16	250	135.700	1.357	179	44
	180								154.200	1.469	193	
	190								164.000	1.526	201	
CTL602 - 260	190	260	395	92	102	12	M16	250	153.000	1.392	167	48
	200								170.400	1.482	161	
	210								180.500	1.536	167	
CTL602 - 280	210	280	425	104	114	16	M16	250	207.300	1.803	180	60
	220								228.300	1.903	171	
	230								253.600	2.030	181	
CTL602 - 300	230	300	460	104	114	18	M16	250	258.900	2.071	172	75
	240								283.700	2.183	181	
	250								312.500	2.315	192	